



Fagor Automation S. Coop.

Manual code: 14460145

Manual version: 1405



ENCODER SAF-D170

MANUAL DE INSTALACIÓN
INSTALLATION MANUAL

FAGOR AUTOMATION S. COOP.

B^a San Andrés N^o 19

Apdo de correos 144

20500 Arrasate/Mondragón

- Spain -

Web: www.fagorautomation.com

Email: info@fagorautomation.es

Tel.: (34) 943 719200

Fax: (34) 943 791712



Fagor Automation S. Coop.

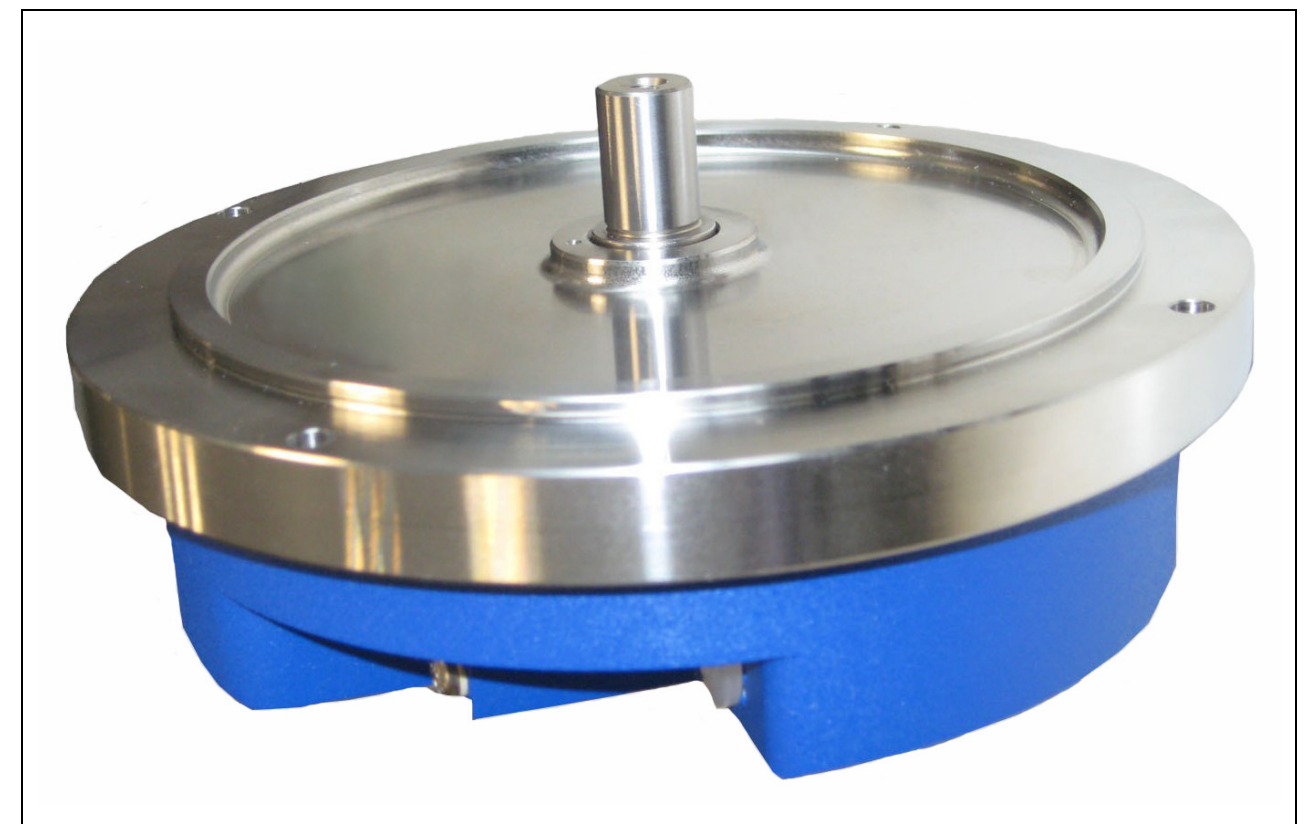

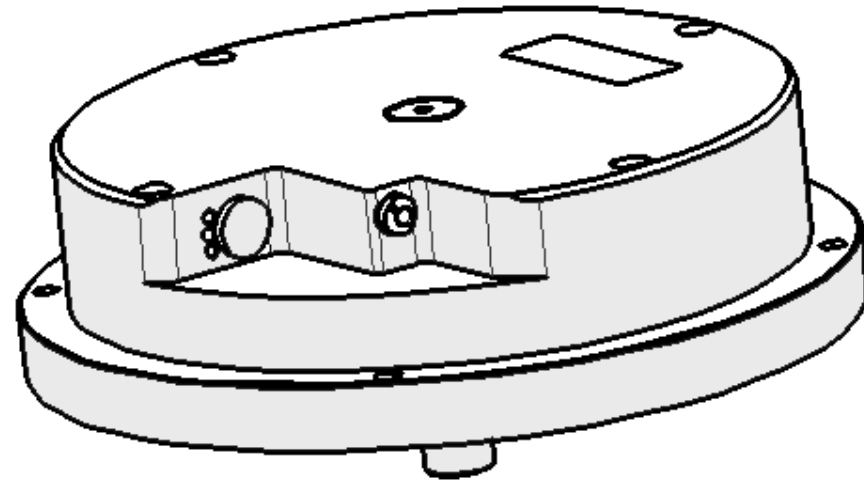

MANUAL



GRÁFICO
GRAPH



ACCESORIOS
ACCESSORIES

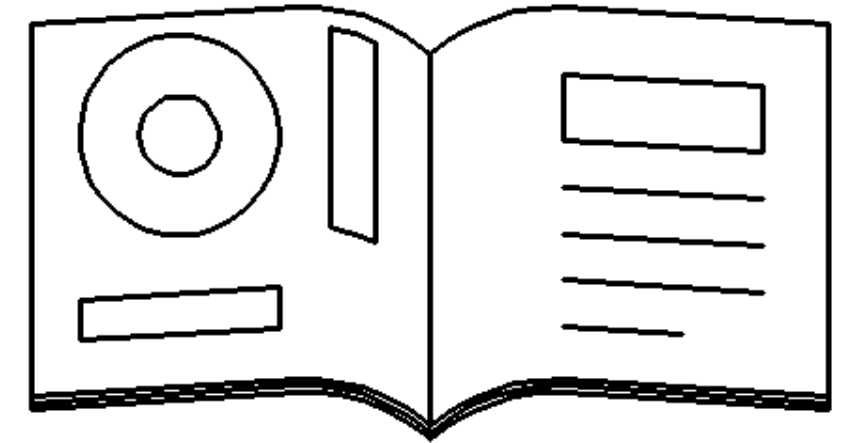
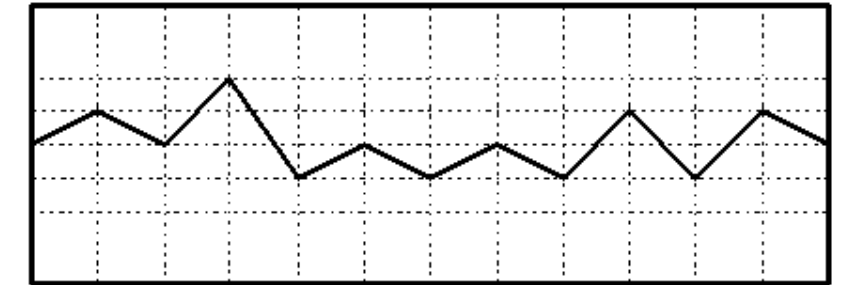
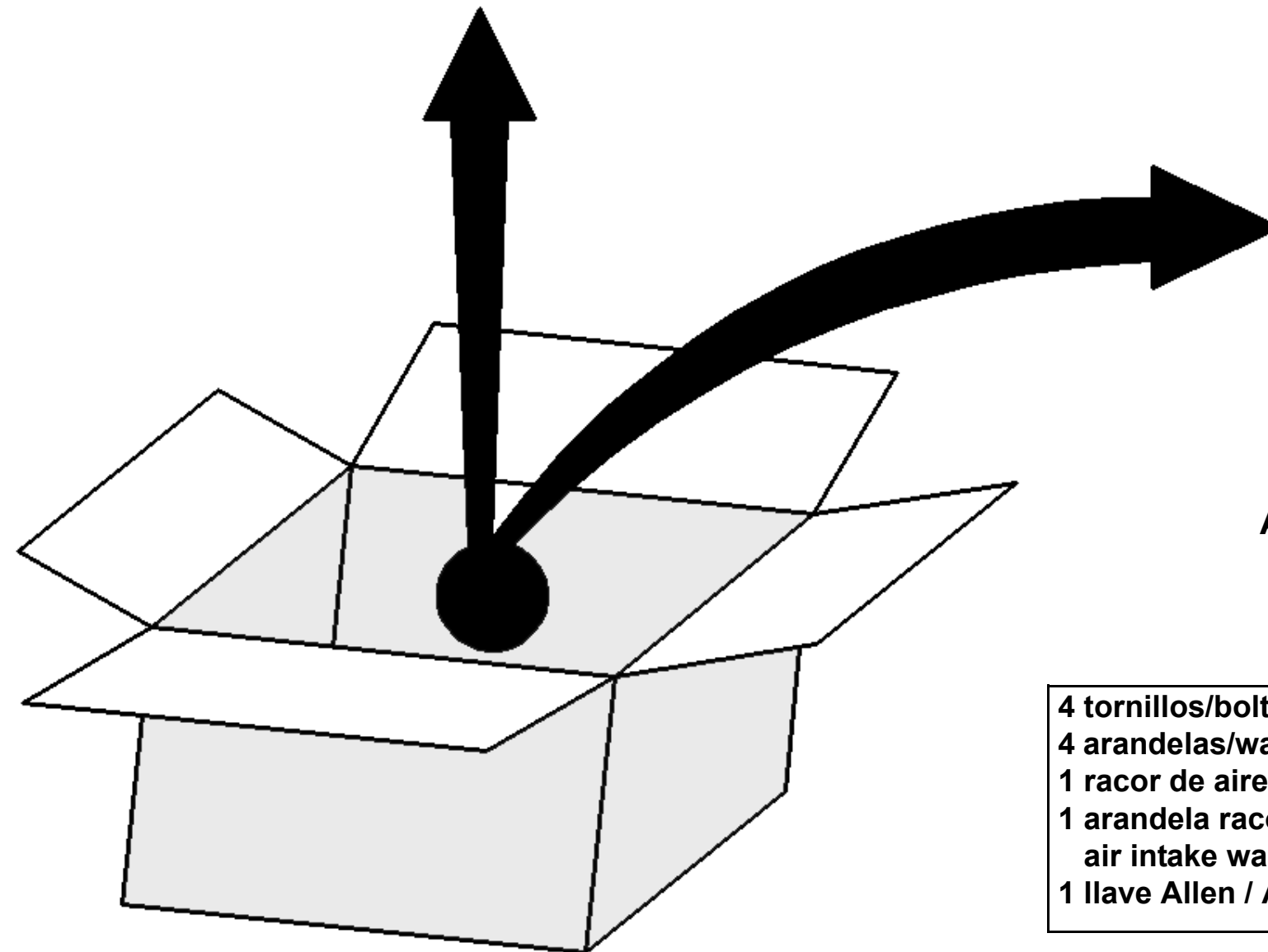
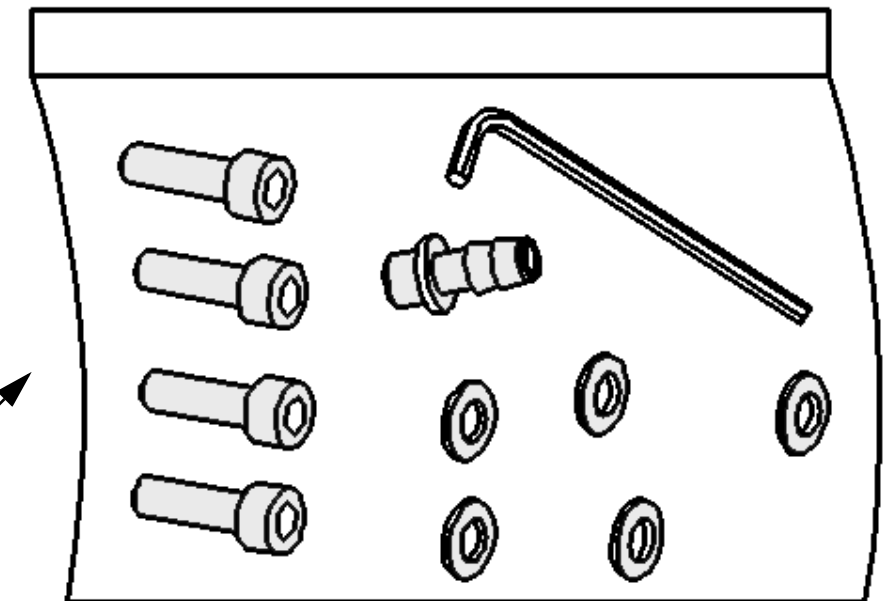

- 4 tornillos/bolts M5 x 25 DIN 912
- 4 arandelas/washers M5 DIN 125
- 1 racor de aire / air intake
- 1 arandela racor de aire /
air intake washer
- 1 llave Allen / Allen wrench

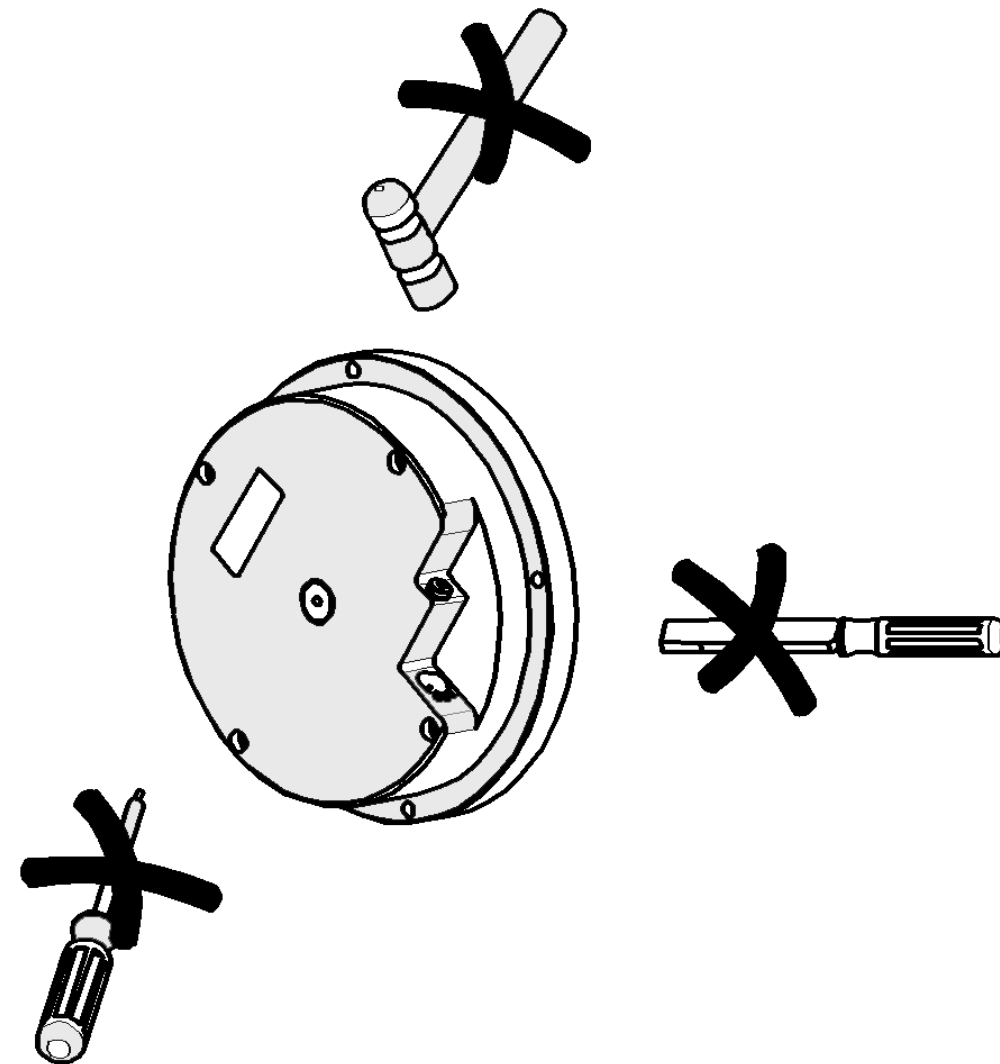
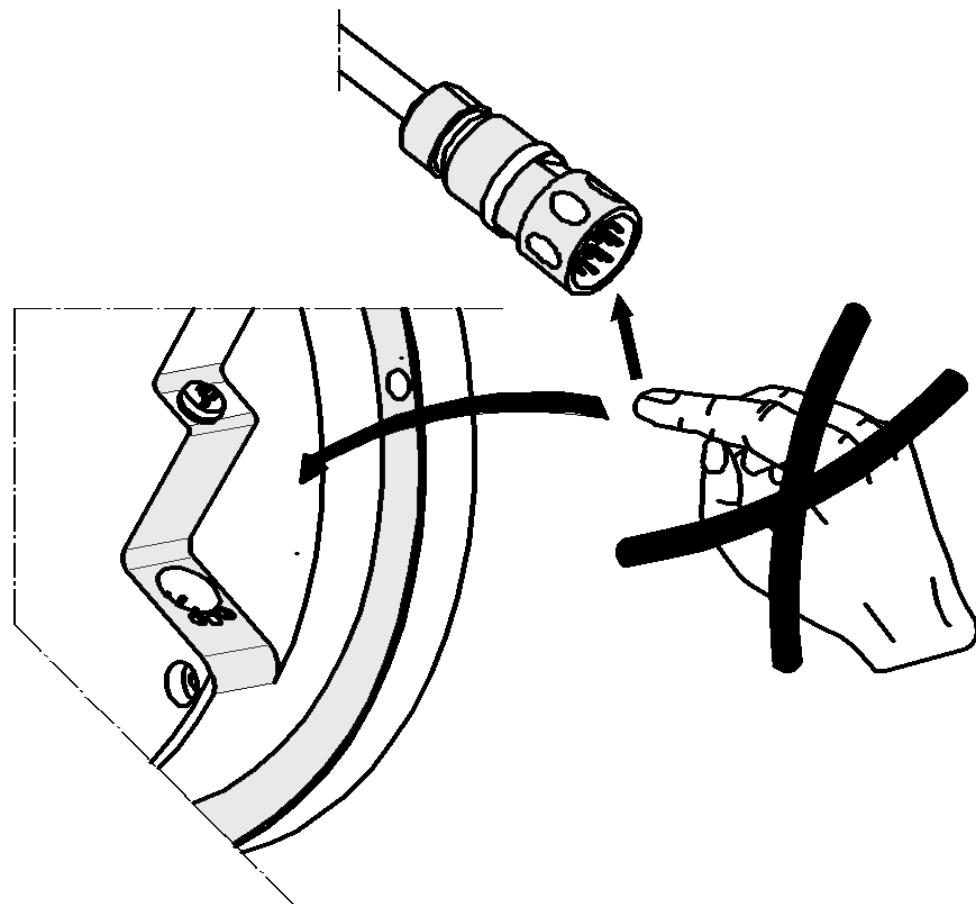
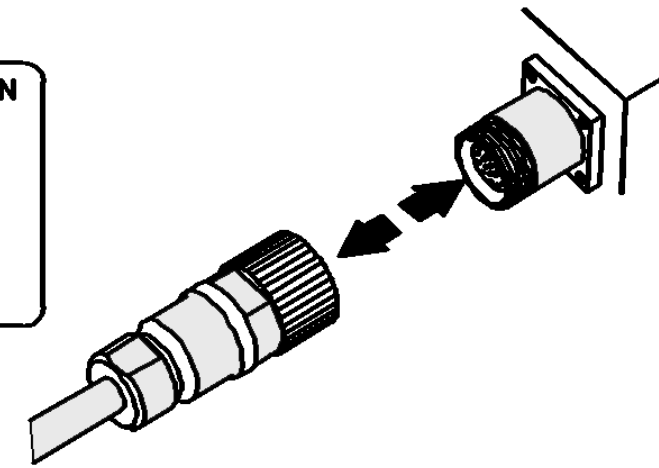
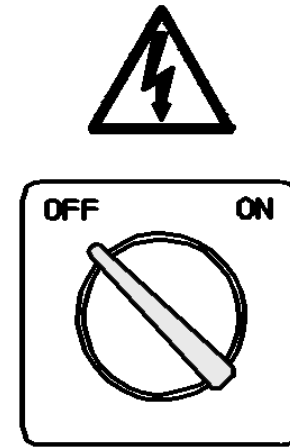
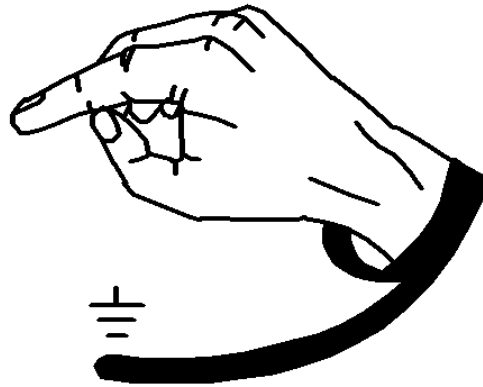

GENERAL DIMENSIONS

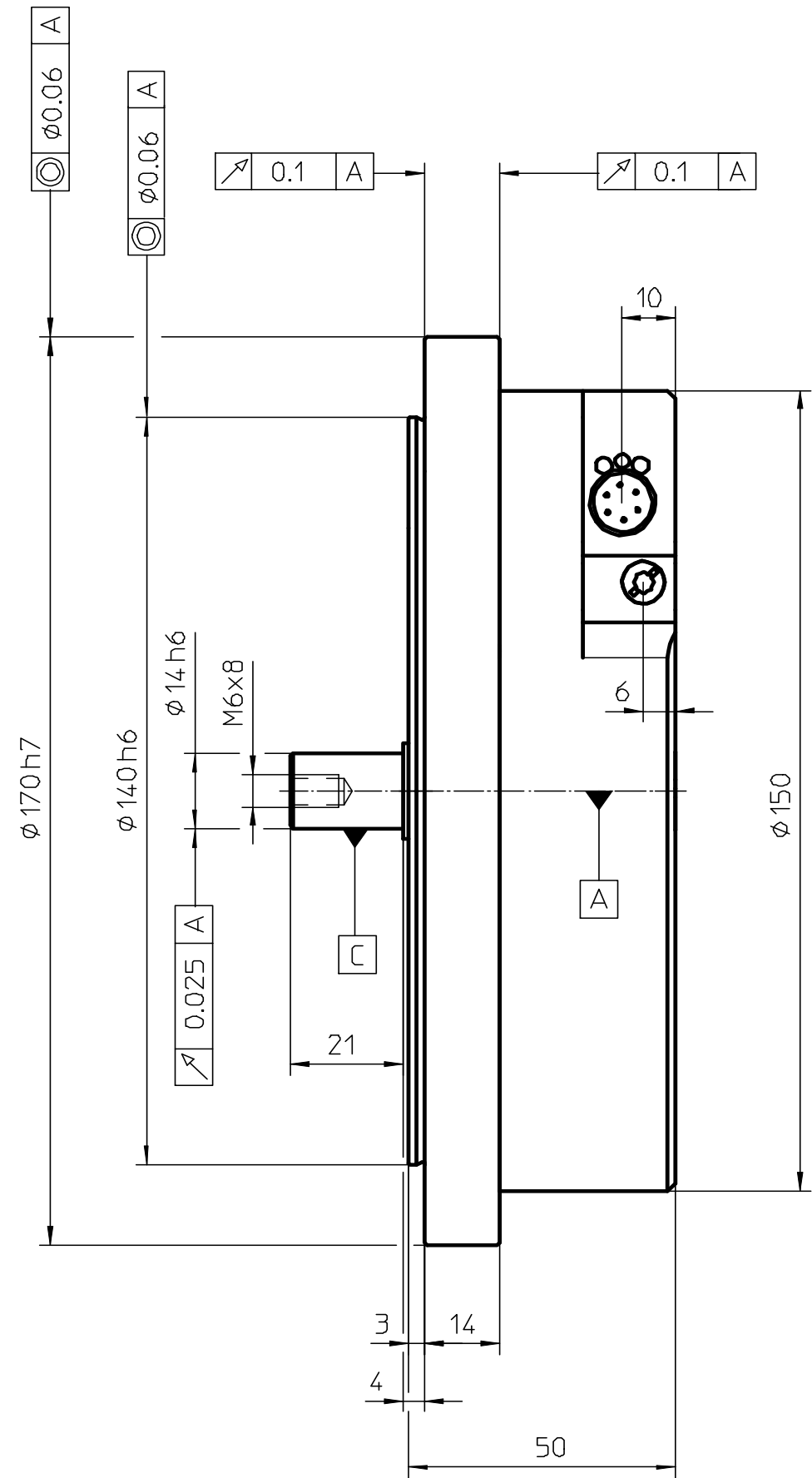
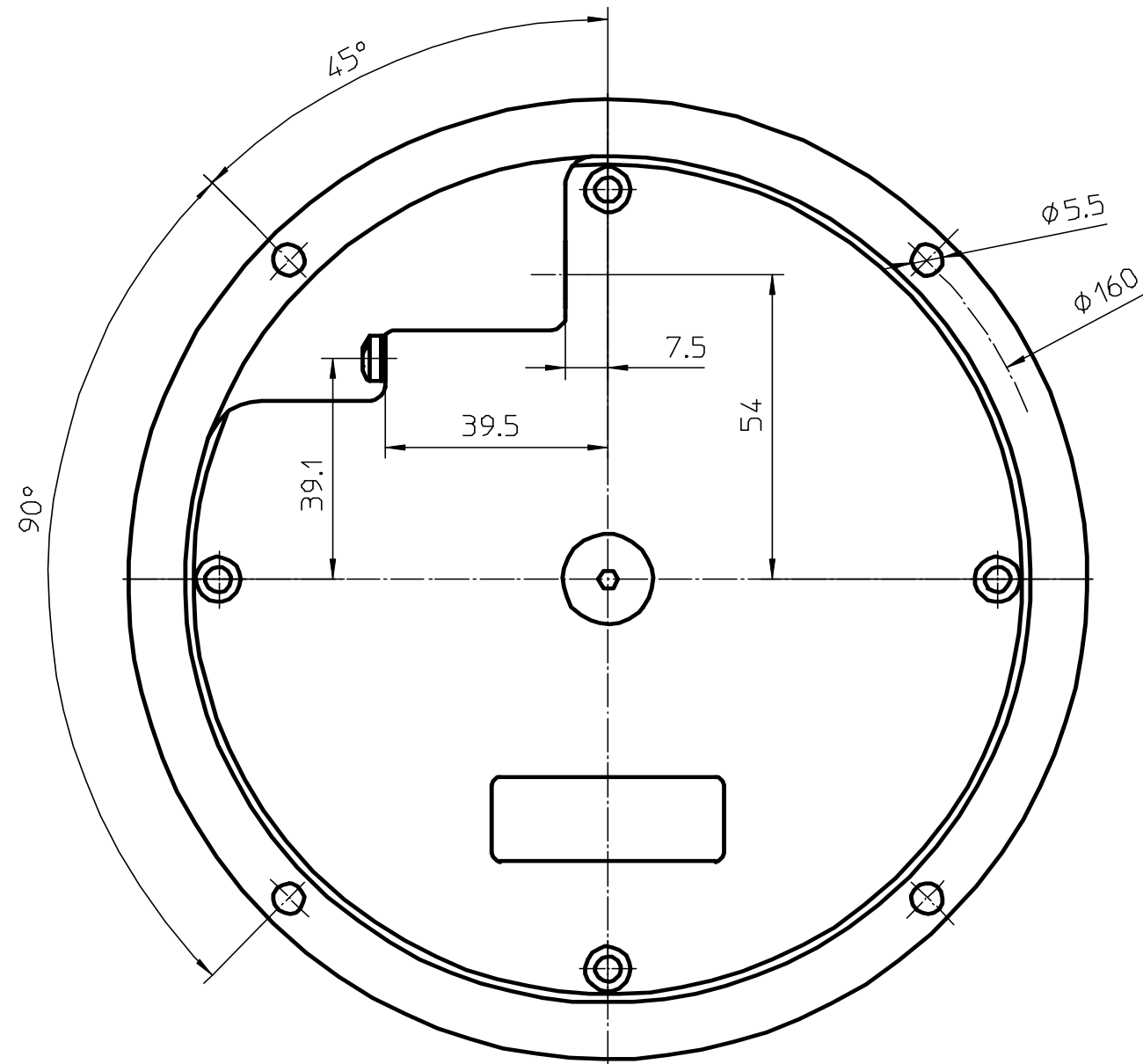

MONTAJE / MOUNTING

Cotas de montaje / Mounting dimensions

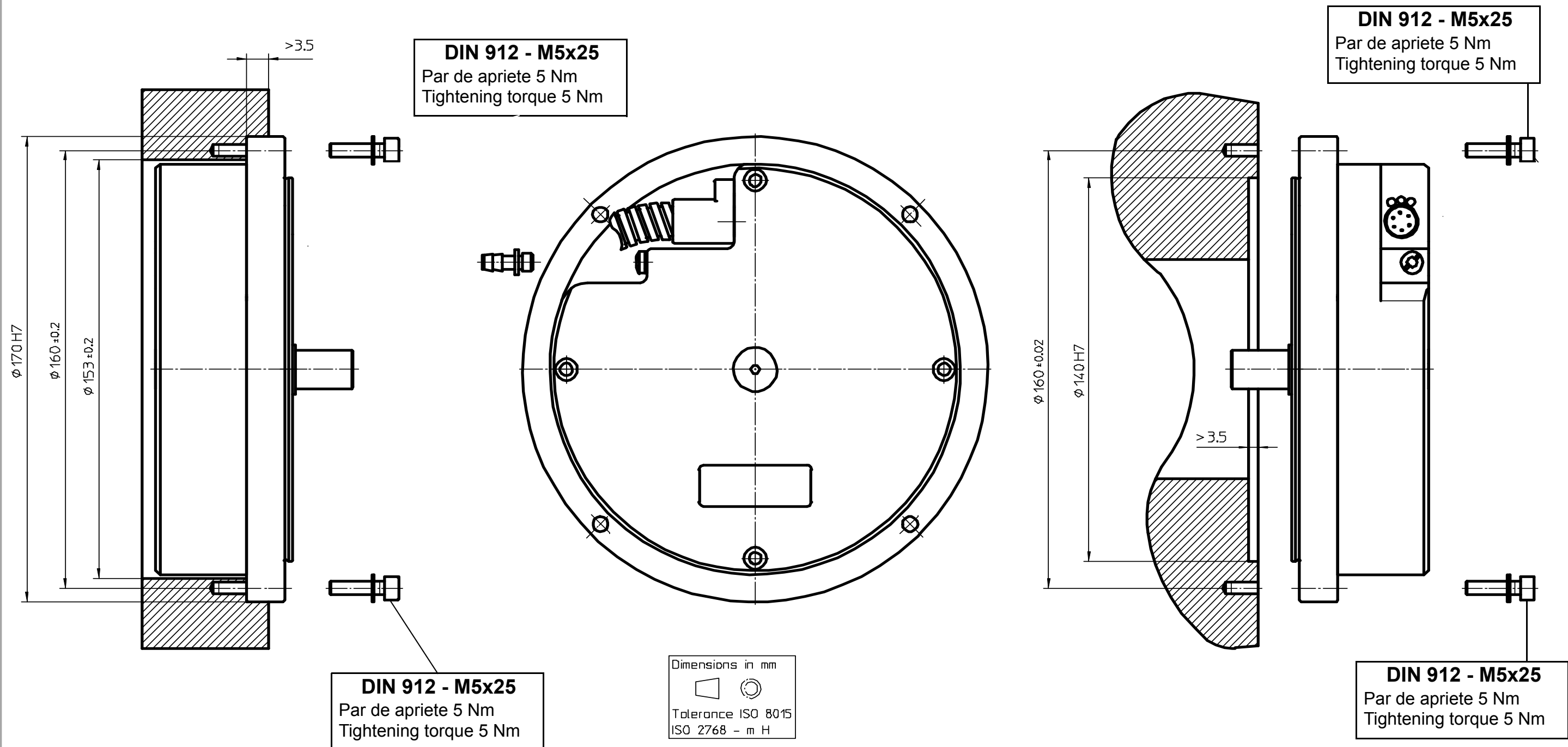

MONTAJE / MOUNTING

Acoplamiento / Coupling

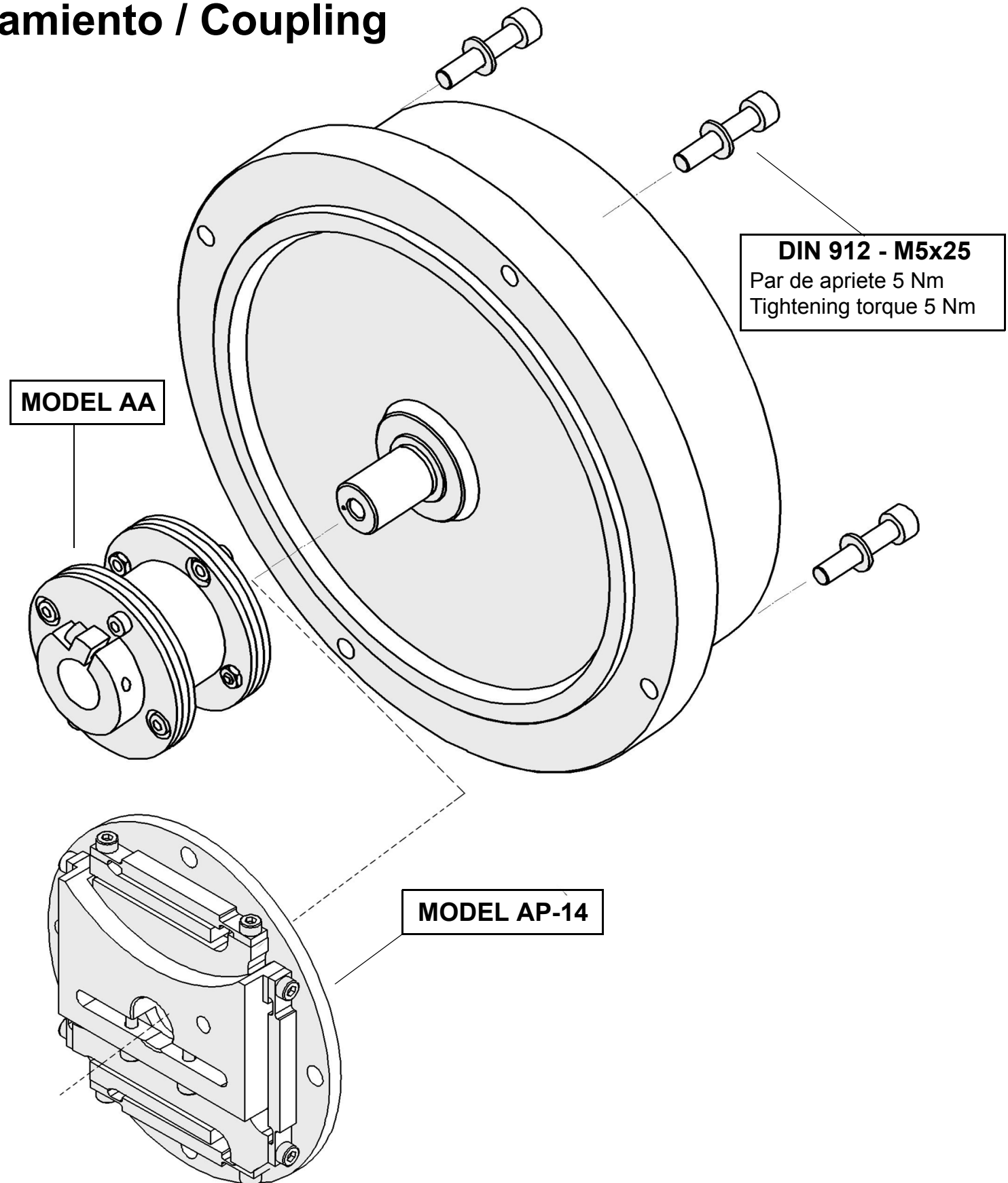
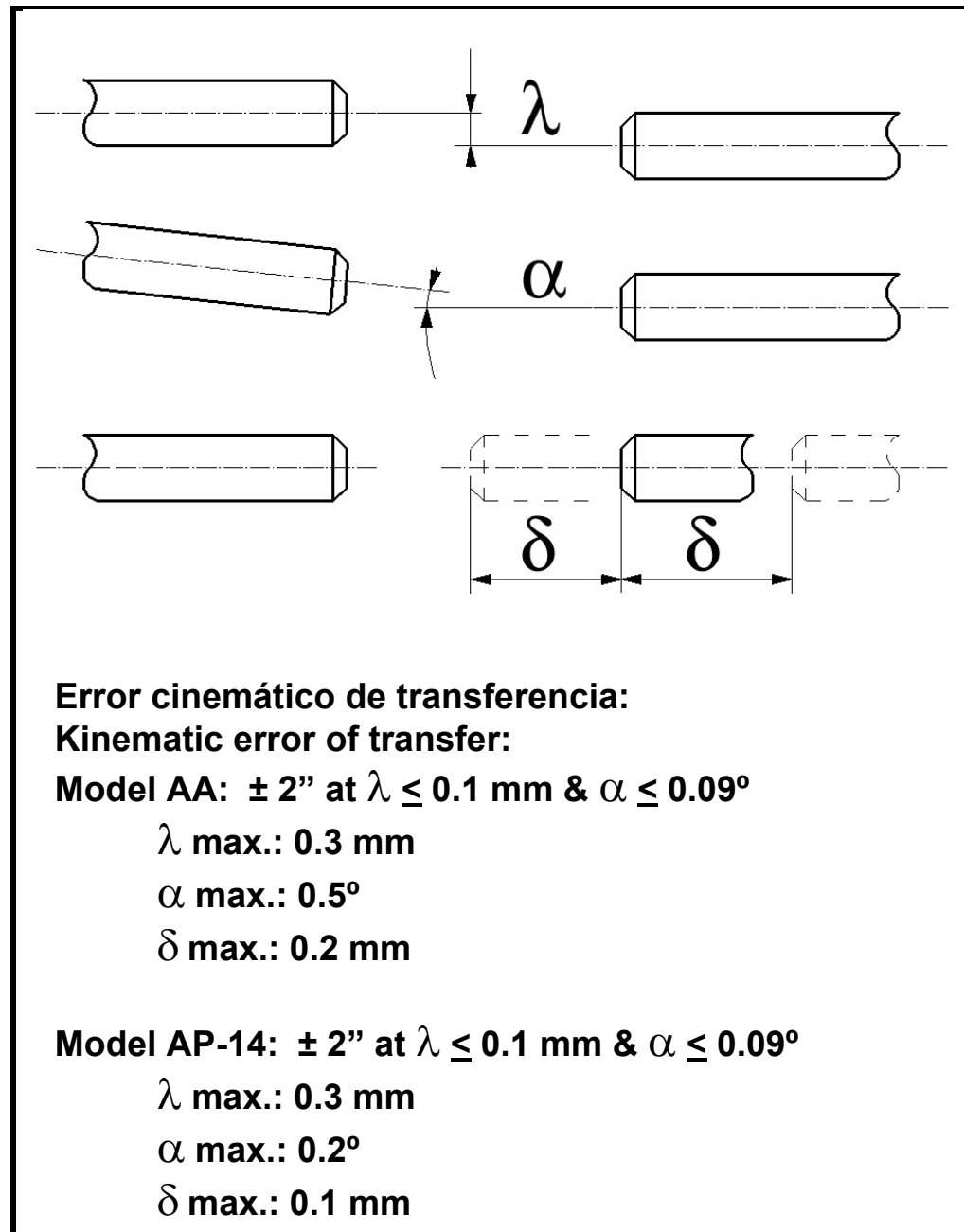

Nivel máximo: IP 64
 Maximum level IP 64

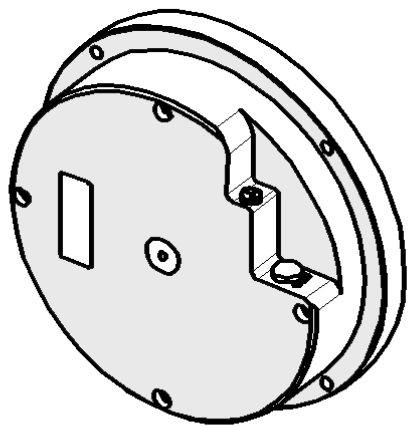

> IP 64

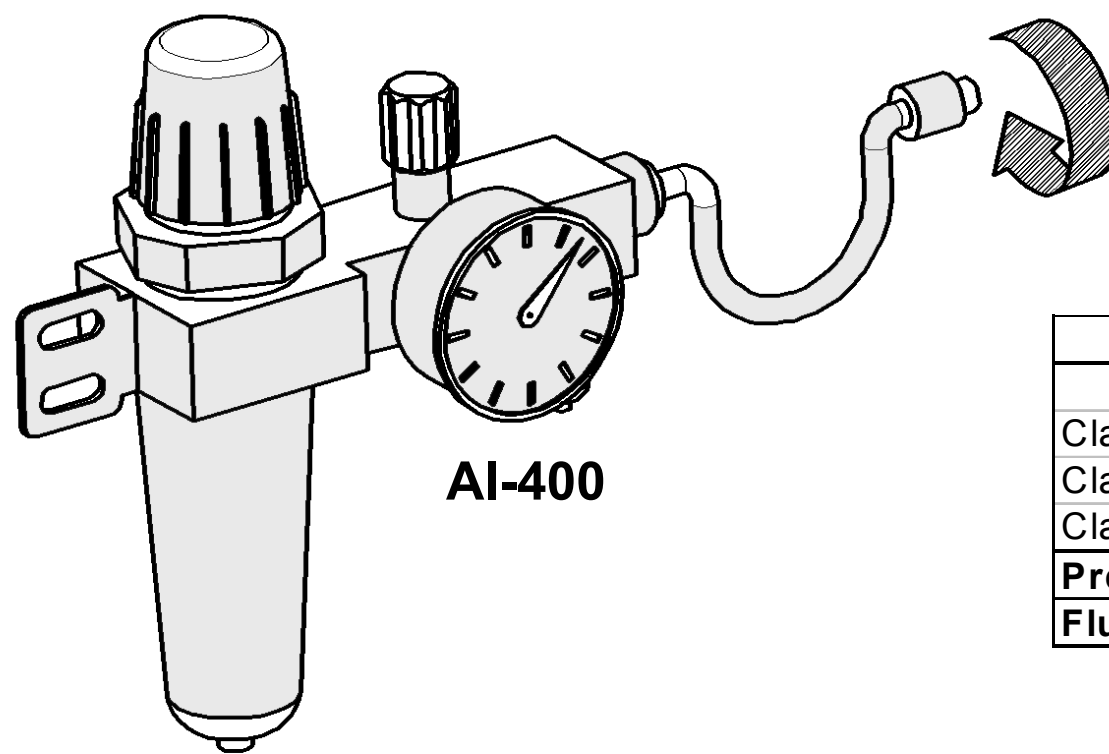

AI-400

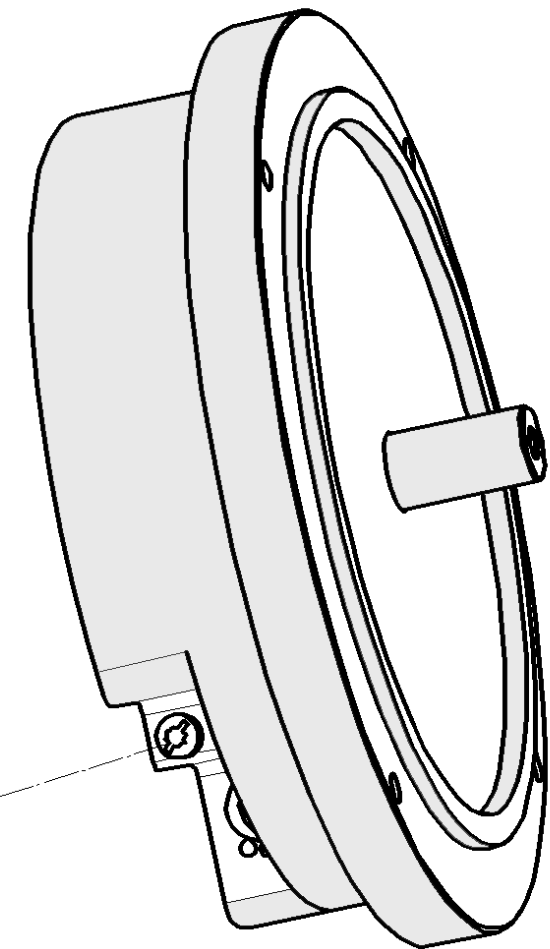
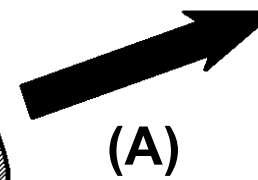

(A) AIR CONDITIONS	
DIN ISO 8573 -1	
Class 1 - Particule Max. 0.1 μ	
Class 4 (7 bar) - Punto rocío / dewpoint 3 °C	
Class 1 - Max. Concentration oil 0.01 mg/m3	
Presión / Pressure	1 Kg / cm3
Flujo / Flow	10 l. / min. / encoder

CARACTERÍSTICAS MECÁNICAS MECHANICAL CHARACTERISTICS

Modelo	SAF-D170-27	Model
Precisión	±2"	Accuracy
Maxima velocidad de giro	3000 rpm *	Max. Turning speed
Momento de inercia del eje	350 gr.cm ²	Inertia of the rotor
Par (20°C)	≤ 0.01 Nm	Torque
Carga axial en el eje	10 N	Axial shaft load
Carga radial al final del eje	10 N	Radial load at the end of the shaft
Peso	2.65 kg	Weight
Estanqueidad	IP-64 (DIN 40050)	Sealing protection
Vibración (50-2000 Hz)	100 m/s ² (IEC 68-2-6)	Vibration (50-2000 Hz)
Impacto (6ms)	1000 m/s ² (IEC-68-2-27)	Impact (6 ms)
Temperatura de funcionamiento	0 °C ... 50 °C (32 °F ... 122 °F)	Operating temperature
Temperatura de almacenamiento	-30 °C ... 80 °C (-22 °F ... 176 °F)	Storage temperature

* Limitación eléctrica = 1500 rpm / *Electrical limitation = 1500 rpm*

CARACTERÍSTICAS ELÉCTRICAS / ELECTRICAL CHARACTERISTICS

	SAF-27-D90-2
Resolución <i>Resolution</i>	27 bit (134 217 728) Pulsos / vuelta <i>pulses / turn</i>
Alimentación <i>Power supply</i>	3.6 V ... 5.25 V, <300 mA
Conexión <i>Connection</i>	Con conector incorporado <i>With built-in connector</i>
Longitud de cable <i>Cable length</i>	100 m 300 feet

Al ser modelo único, igual no hace falta poner esta línea

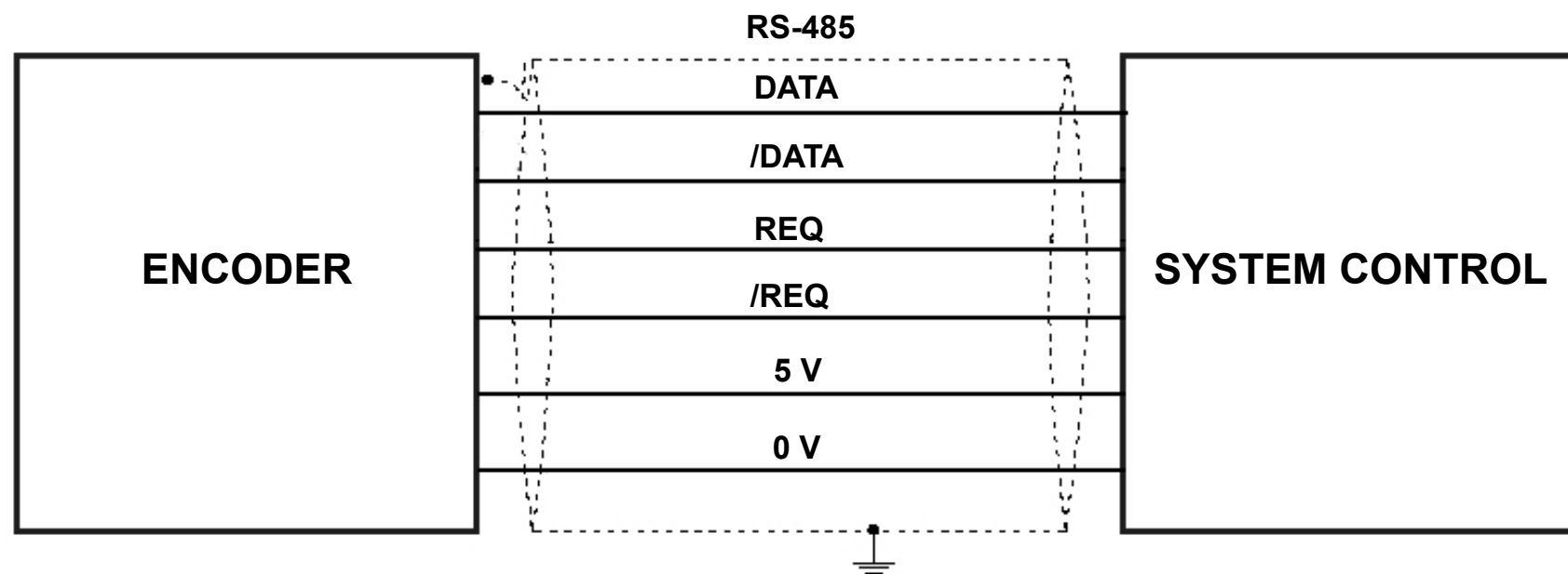

Posición del origen 0°
0° origin position

Girar eje para alinear puntos
Turn the shaft lining up the dots

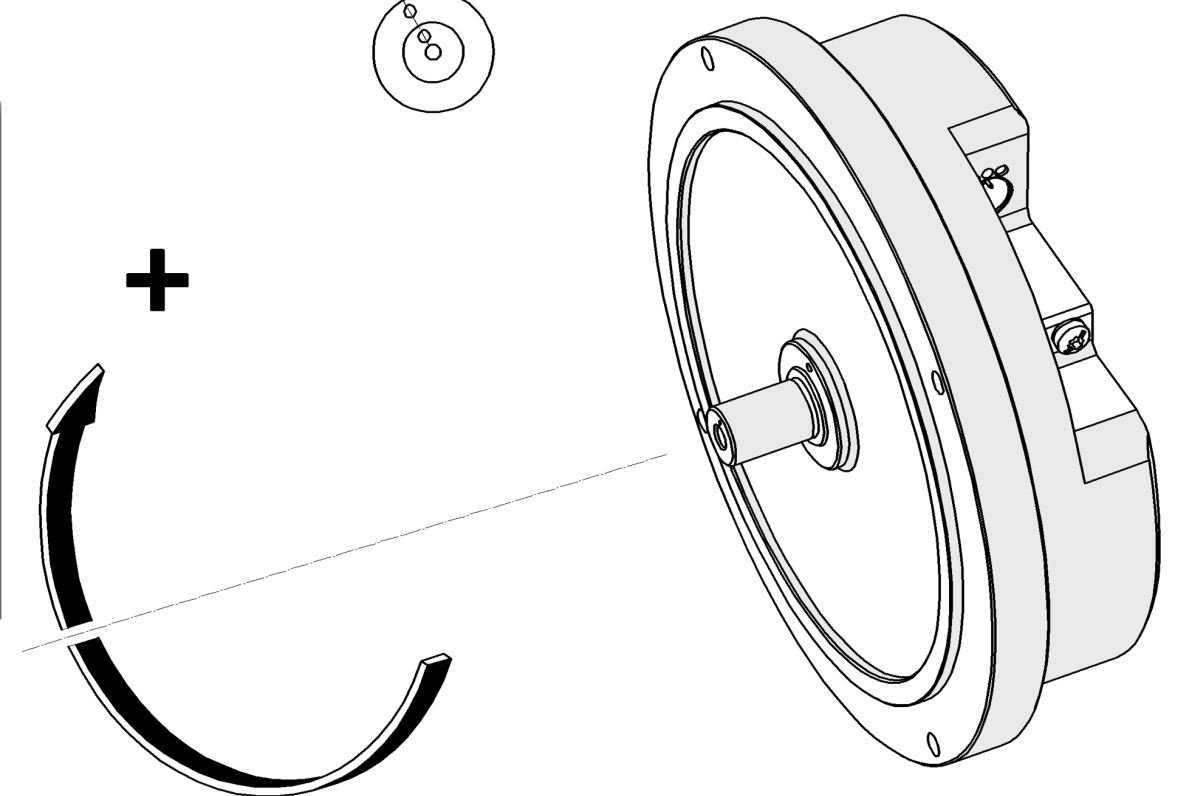

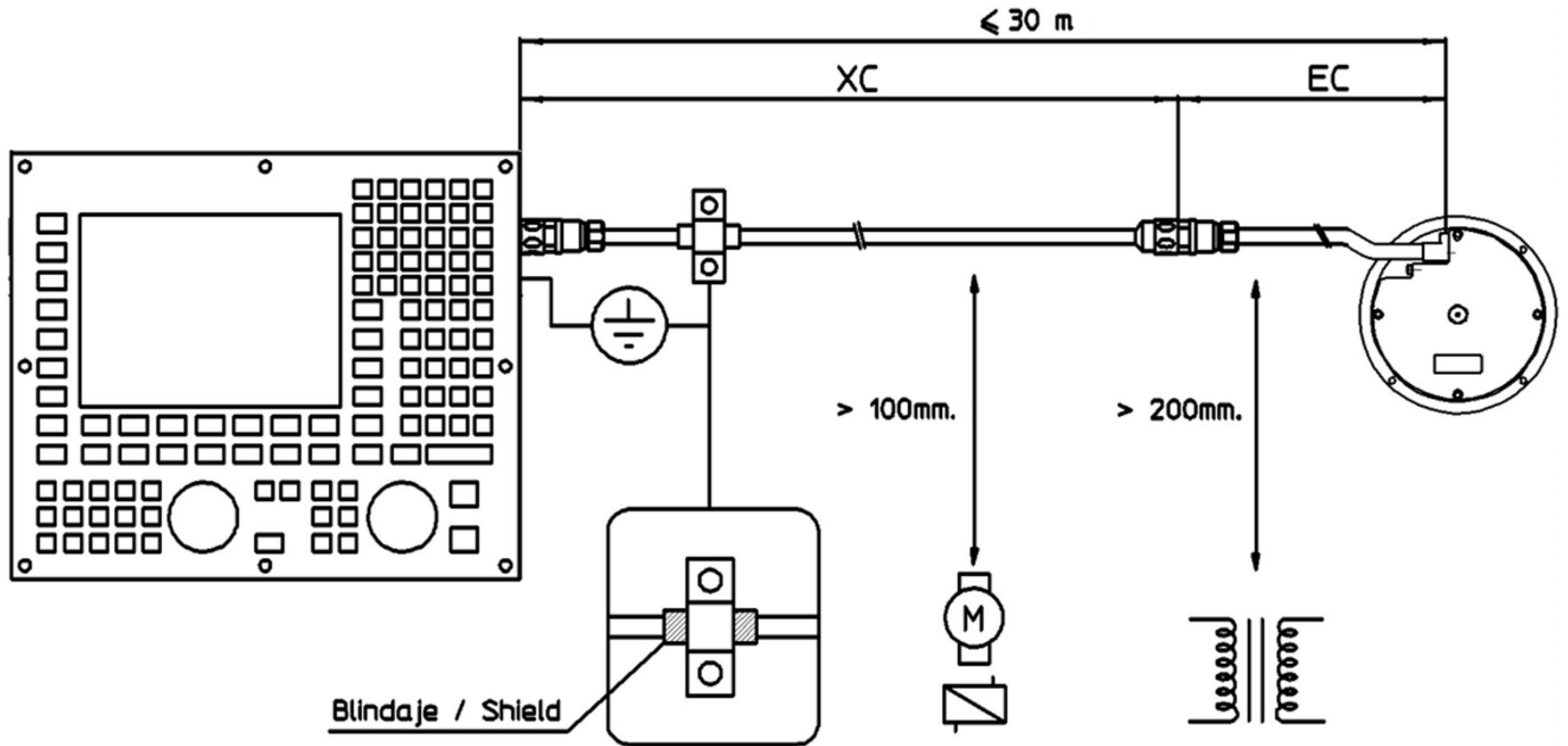

AI 590

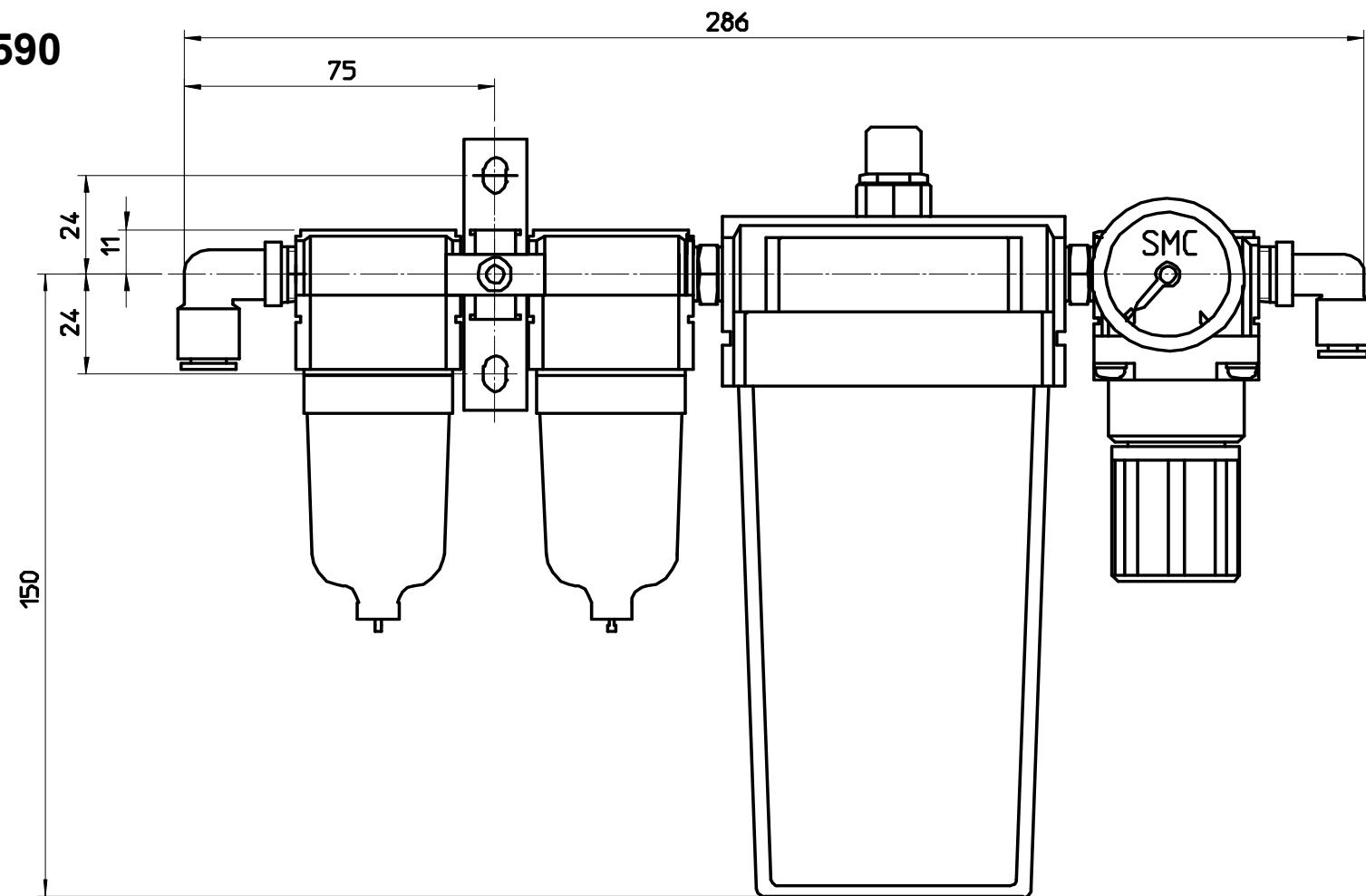

FILTROS DE AIRE / AIR FILTERS

2200000	AI 400	25 l/min
2200001	AI 525	(25l/min)
2200002	AI 550	(50 l/min)
2200003	AI 590	(90 l/min)

AI 525 / AI 550

AI 400

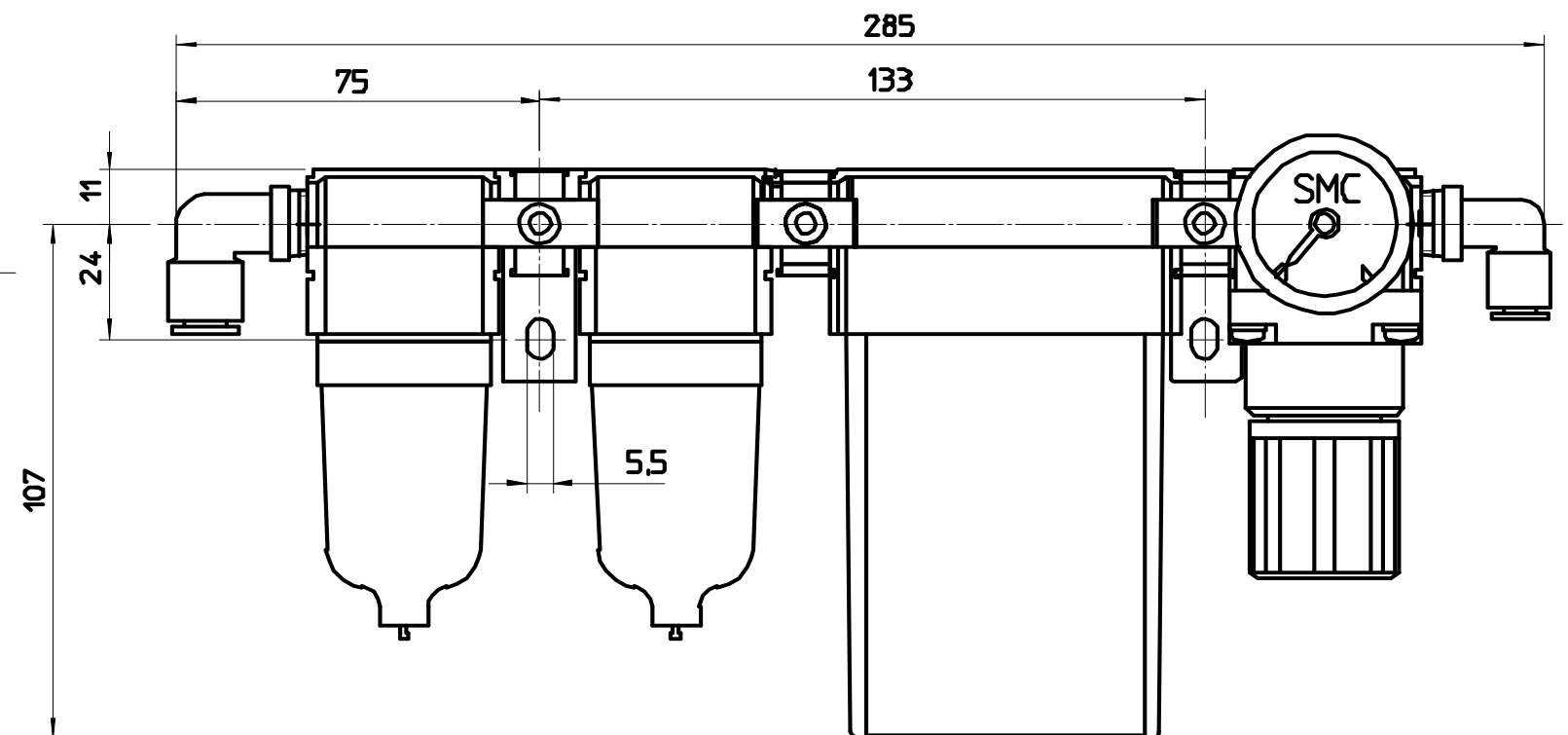
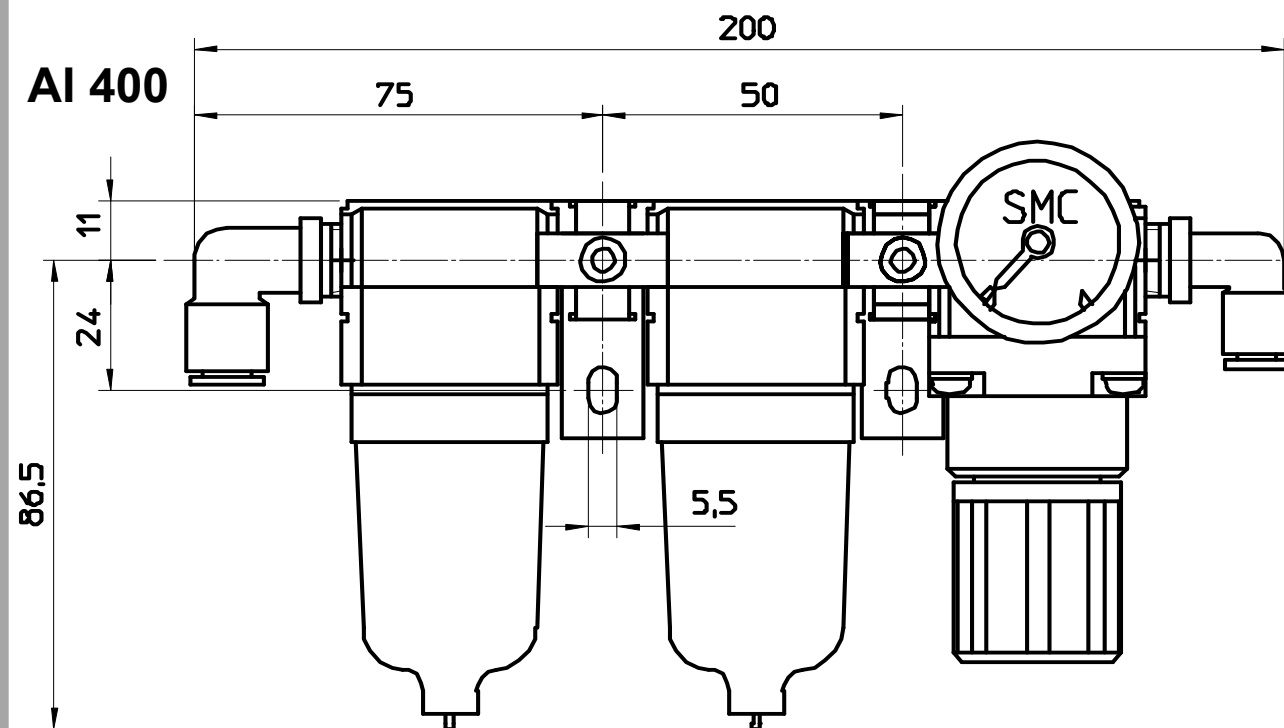

FANUC: CONEXIONES / CONNECTIONS

EC...PA...FN Cable para **conexión directa** a controles absolutos FANUC (segunda captación). Disponible en 1, 3, 6 and 9 metros.
 Cable for **direct connection** to FANUC absolute controllers (second feedback). Available in 1, 3, 6 and 9 meters.

Conector hembra tipo HONDA/HIROSE <i>type female connector</i>									
PIN	9	18-20	12	14	1	2	5	6	16
SEÑAL SIGNAL	+5V	+5V sensor	0V	0V sensor	DATA	/DATA	REQUEST	/REQUEST	Tierra Ground
COLOR	Marrón Brown	Gris Grey	Blanco White	Rosa Pink	Verde Green	Amarillo Yellow	Azul Blue	Rojo Red	

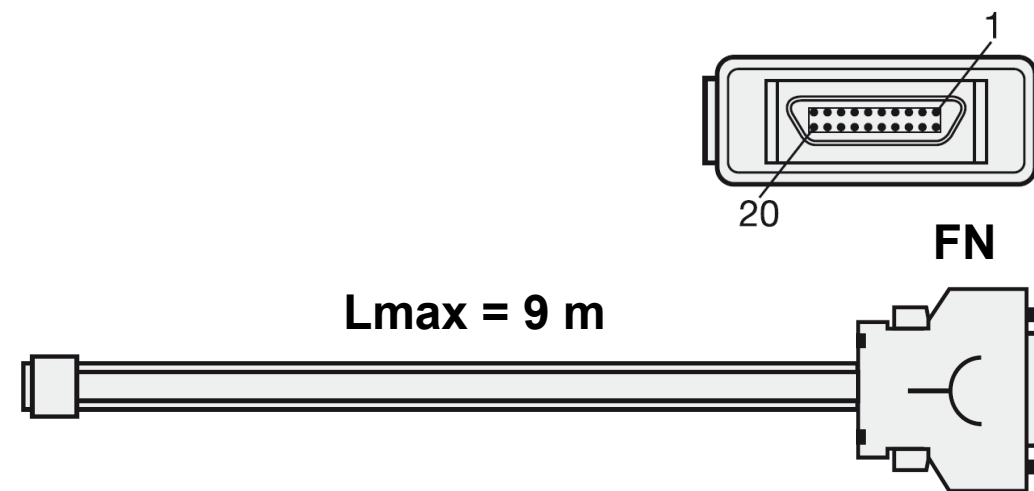

FANUC: CONEXIONES / CONNECTIONS

También se puede utilizar la combinación de un cable **EC...B...C9** con una alargadera **XC...C8...FN** para otras longitudes.
*A combination of **EC...B...C9** cable and an **XC...C8...FN** extension cable may be used for other lengths.*

EC...B...C9 Cable disponible en 1 y 3 metros. Contactar con FAGOR para otras longitudes.
Cable available in 1 and 3 meters. Contact FAGOR for other lengths.

Conector macho circular 17 <i>male connector</i>									
PIN	7	1	10	4	14	17	8	9	Caperuza Housing
SEÑAL SIGNAL	+5V	+5V sensor	0V	0V sensor	DATA	/DATA	REQUEST	/REQUEST	Tierra Ground
COLOR	Marrón Brown	Gris claro Light grey	Blanco White	Naranja Orange	Gris Grey	Rosa Pink	Negro Black	Violeta Purple	Malla interna Internal shield

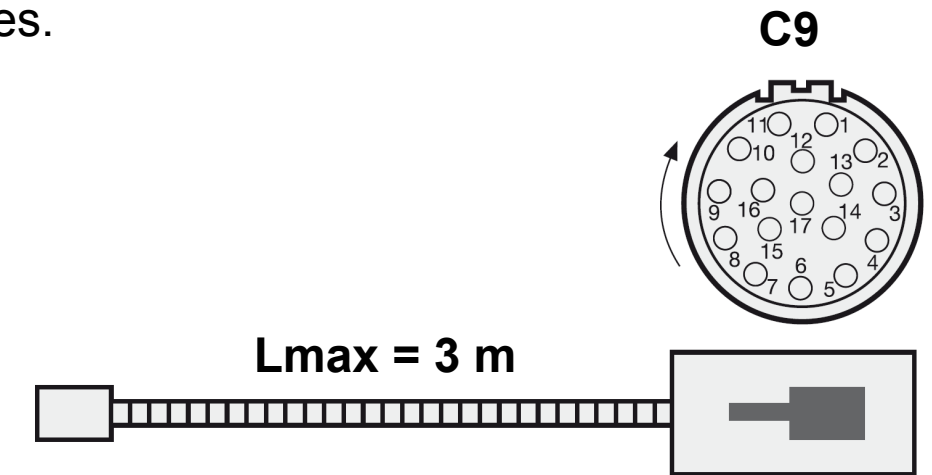

XC...C8...FN Alargadera disponible en 5, 10, 15, 20 y 25 metros.
Extension cable available in 5, 10, 15, 20 and 25 meters.

Conector (C8) hembra circular 17 <i>female connector</i>									
PIN	7	1	10	4	14	17	8	9	Caperuza Housing
Conector (FN) hembra rectangular 20 <i>HONDA/HIROSE female rectangular connector</i>									
PIN	9	18-20	12	14	1	2	5	6	16
SEÑAL SIGNAL	+5V	+5V Sensor	0V	0V sensor	DATA	/DATA	REQUEST	/REQUEST	Malla Shield
COLOR	Marrón-verde Brown-green	Azul Blue	Blanco-verde White-green	Blanco White	Gris Grey	Rosa Pink	Violeta Purple	Amarillo Yellow	Negro Black

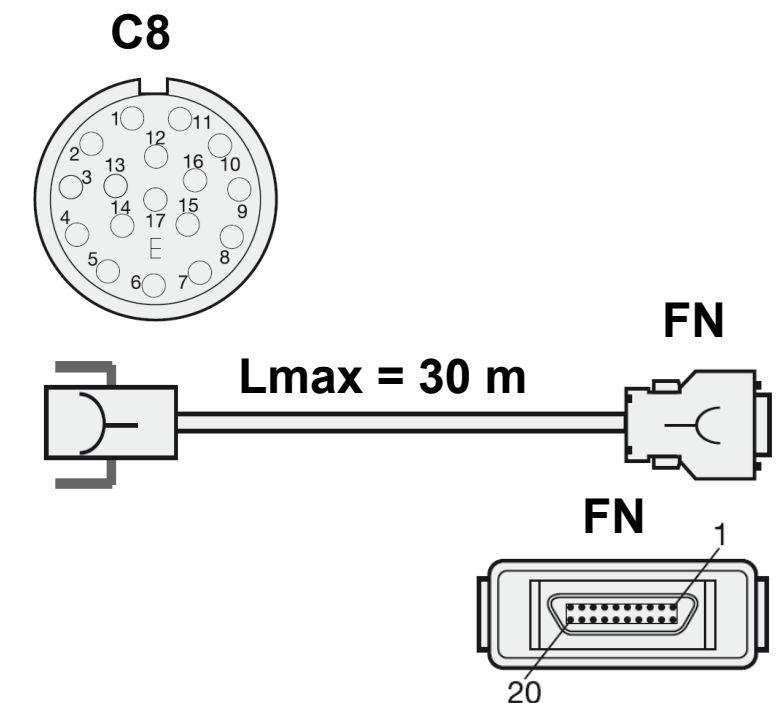

GARANTIA

- *Plazo: 12 meses a partir de la fecha de expedición de fábrica.
- *Cubre gastos de Materiales y Mano de Obra de reparación en FAGOR AUTOMATION.
- *Los gastos de desplazamiento son a cargo del cliente.
- *No cubre averías por causas ajenas a FAGOR AUTOMATION, como: golpes, manipulación por personal no autorizado, etc.

DECLARACION DE CONFORMIDAD

Fabricante: Fagor Automation, S. Coop.
Barrio de San Andrés 19, C.P. 20500, Mondragón -Guipúzcoa- (ESPAÑA)

Declaramos bajo nuestra exclusiva responsabilidad la conformidad del producto al que hace referencia este manual

Nota. Algunos caracteres adicionales pueden seguir a las referencias de los modelos indicados en este manual. Todos ellos cumplen con las siguientes normas:

COMPATIBILIDAD ELECTROMAGNÉTICA:

EN 61000-6-2:2005 Norma de Inmunidad en entornos industriales
EN 61000-6-4:2007 Norma de Emisión en entornos industriales

De acuerdo con las disposiciones de la Directiva Comunitaria: 2004/108/CE de Compatibilidad Electromagnética.

Mondragón a 1 de Mayo de 2011

Fagor Automation, S. Coop.

Director Gerente
Pedro Ruiz de Aguirre

WARRANTY

- *Term: 12 months from factory invoice date.
- *It covers parts and labor at FAGOR AUTOMATION.
- *Travel expenses are payable by the customer.
- *Damages due to causes external to FAGOR AUTOMATION, such as unauthorized handling, blows, etc. are not covered.

DECLARATION OF CONFORMITY

Manufacturer: Fagor Automation, S. Coop.
Barrio de San Andrés 19, C.P. 20500, Mondragón -Guipúzcoa- (SPAIN)

We declare under our exclusive responsibility the conformity of the product referred to in this manual.

Note. Some additional characters may follow the model references indicated in this manual. They all comply with the following regulations:

ELECTROMAGNETIC COMPATIBILITY:

EN 61000-6-2:2005 Standard on immunity in industrial environments
EN 61000-6-4:2007 Standard on emission in industrial environments

According to the European Directive: 2004/108/CE on electromagnetic compatibility.

Mondragón Mayo 1st 2011

